

Assembly instructions for (CB or PMR) Radio Junctionbox to GL1800 / GL1500

Installation and connecting of the Radio-Junctionbox

The Junctionbox will be installed under the front left storage compartment. Remove the storage compartment. Disconnect the 6-pole plug of the Intercom cable from the cable harness. Connect now the open sockets with the cable harness of the Junctionbox. Connect the 2 single plugs coming from Junctionbox harness with the (CB or PMR) radio.

For AM CB-Radio devices it is extremely important to provide a solid connection of the antenna with the ground of the vehicle frame and also to adjust the wave frequency of the antenna to the utmost.

Install the PTT switch (transmission switch) at the left end of the handlebar. The clutch-lever screw fastens the switch. Loosen the screws for the cable groove at the handlebar, however do not completely unscrew them. Press the cable of the PTT switch into the cable groove, and then tighten the screws again. Place the cable around the fork cross-beam and connect it to the socket of the junctionbox harness.

Decide on a separate place to install the (CB/PMR) Radio. Forward both cables of the jack plug (2,5 mm and 3,5 mm) and insert them into the corresponding sockets of the radio.

As soon as all connections are made, the installation is ready to be used.

Operation of the Radio

Start the (CB/PMR) Radio and choose a medium volume. Connect the helmet. Switch on the ignition (ACC position). Switch on the Intercom and setting an average volume.

Check the Intercom and the (audio) radio, both should still work via the helmet. Start the squelch or check by transmitting with a second radio on the same channel. If all connections are made correctly, you should hear the noise or the other radio in the helmet with an acceptable volume. Using the volume control of the (CB/PMR) radio the volume may be adjusted. As soon as the second radio is no longer active, you should be able to listen to the normal radio/ Intercom function. Press the PTT switch (at the handle bars) and check the communication from your motorbike to the other Radio. The junctionbox is pre-installed and should work with standard plug distribution.

At the End

If everything works, place and secure the cables. Secure the junctionbox against humidity and splashing. A plastic bag may be fixed around the box and the plugs. Secure the bag with adhesive tape. Re-install all previously dismantled parts and double check everything.

In case of occurring problems, please contact us at +49(0)4122 967690. We help you.



Klinkerstrasse 7, 25436 Moorrege, Germany
Phone 0049 4122 967690, Fax 0049 4122 967689
Mail irlbacher@w-irlbacher.de, www.w-irlbacher.de

Terminal plan for radio equipment with its own power supply

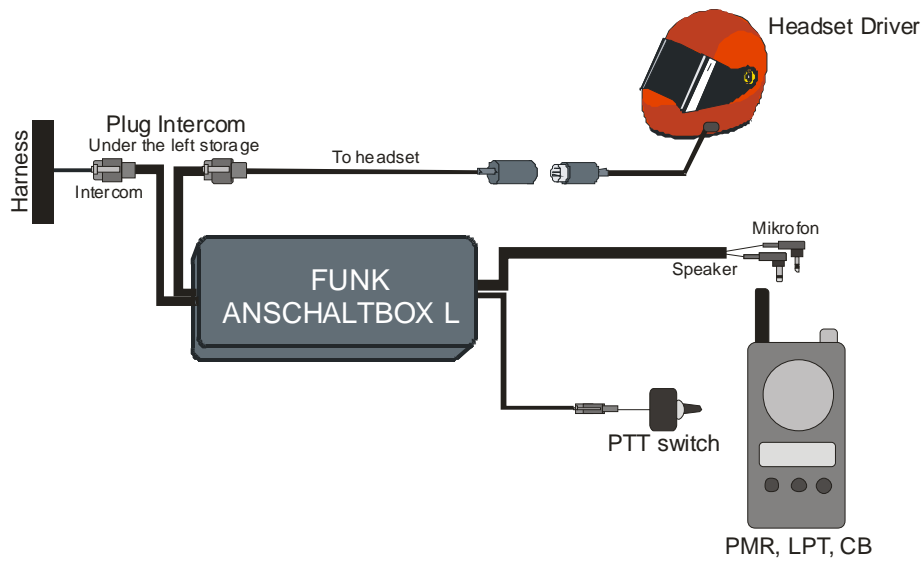

Terminal plan for cb radio Alan 42

